

PRINCIPLE

RF-Capacitance level Transmitter utilizes the capacitance formed between the sensing probe and the reference probe which is the metallic vessel wall to calculate the level of the liquid/medium inside the vessel according to the capacitance theory that the capacitance and vessel are proportional increased.

RF-Capacitance level Transmitter utilizes RC oscillating circuit to create a high frequency signal in which the frequency is reverse proportionate to the capacitance C where the microprocessor is applied to measure the frequency for calculating the capacitance and corresponding to the level in order to control the current volume of 2 wire loop power.

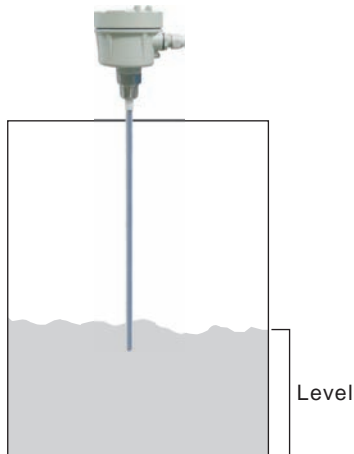

FEATURES

- 4~20mA 2 wire Loop power
- Low consumption of power (20mA Max)
- High accuracy of linearity ($\pm 1\%$ FS)
- Temperature compensation, low temperature effect ($\pm 1\%$ FS / 30°C).
- Easy calibration (Any 2 points for calibration)
- Wide measuring range for capacitance (0~2000PF)
- No blind distance, ideal for different tanks.
- Suitable for high temperature, high pressure and corrosive environment.

APPLICATION

- Brewery Plant
- Paint Manufacturing Plant
- Cement Plant
- Food Processing Plant
- Flour Mill
- Glass Industry
- Water And Waste Water Treatment
- Medical Plant
- Power Plant
- Tar Factory
- Beverage Plant
- Plastic Plant

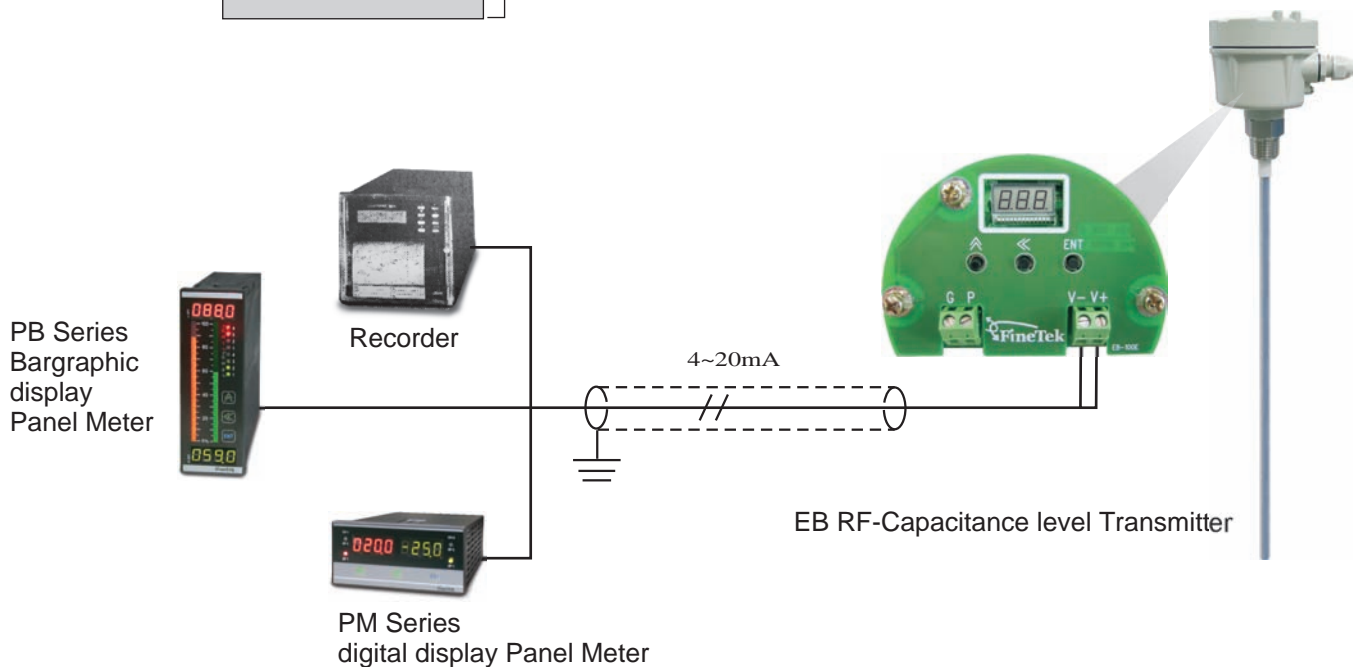

STANDARD SPECIFICATION

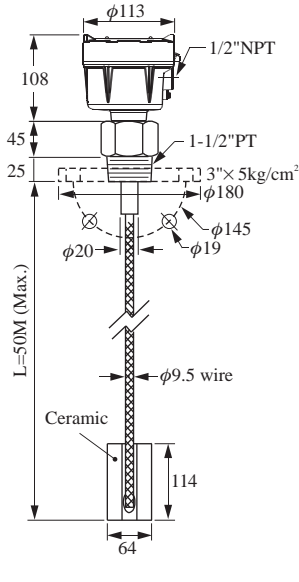
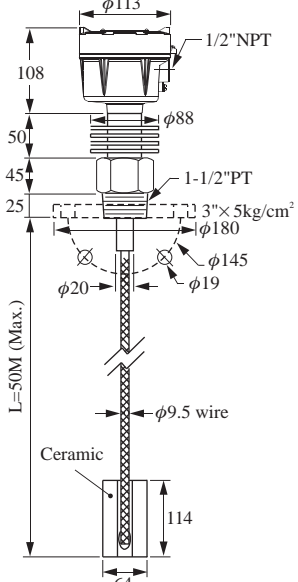
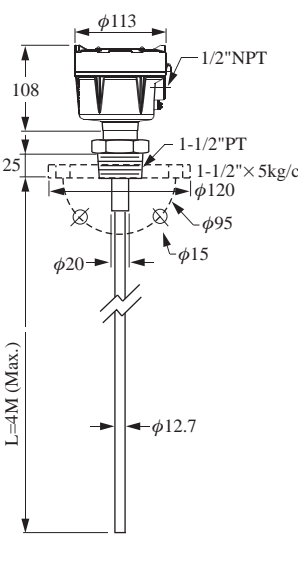
Dimensions (unit:mm)			
Model No.	EB2100 Wire Probe	EB2101 Hi-Temp Wire Probe	EB2200 Rod Probe
Probe material	SUS304	SUS304	SUS304/316
Weight material	CERAMIC	CERAMIC	————
Ambient Temperature	-40~80°C	-40~80°C	-40~80°C
Operating temperature	0~100°C	0~200°C	0~100°C
Tensile strength	3500Kgf	3500Kgf	————
Operation voltage	12~36Vdc	12~36Vdc	12~36Vdc
Output current	4 ~20mA	4 ~20mA	4 ~20mA
Measuring Range	0~2000pF	0~2000pF	0~2000pF
Accuracy	± 1%FS	± 1%FS	± 1%FS
Housing IP Degree	IP65	IP65	IP65
Connection	3"x5kg/cm ² or 1-1/2"PT Screw	3"x5kg/cm ² or 1-1/2"PT Screw	1-1/2"x5kg/cm ² or 1-1/2"PT Screw
Weight	Approx. 3.7kg(1M)	Approx. 4.2kg(1M)	Approx. 2.3kg(1M)
Operating pressure	15kg/cm ²	15kg/cm ²	15kg/cm ²

STANDARD SPECIFICATION

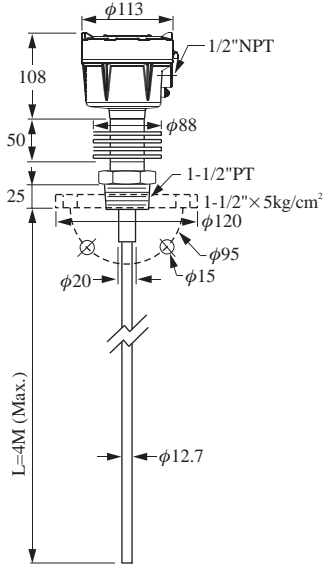
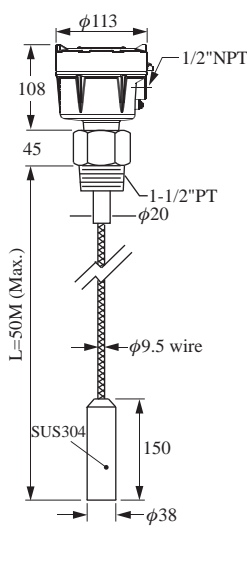
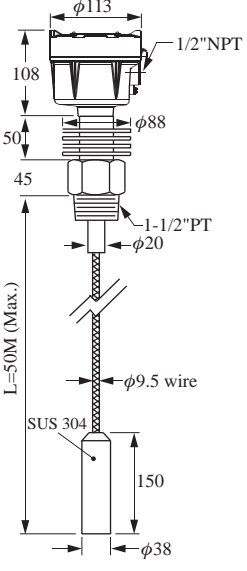
Dimensions (unit:mm)			
Model No.	EB2201 Hi-Temp Rod Probe	EB2300 Wire Probe	EB2301 Hi-Temp Wire Probe
Probe material	SUS304/316	SUS304	SUS304
Weight material	————	SUS304	SUS304
Ambient Temperature	-40~80°C	-40~80°C	-40~80°C
Operating temperature	0~200°C	0~100°C	0~200°C
Tensile strength	————	3500Kgf	3500Kgf
Operation voltage	12~36Vdc	12~36Vdc	12~36Vdc
Output current	4 ~20mA	4 ~20mA	4 ~20mA
Measuring Range	0~2000pF	0~2000pF	0~2000pF
Accuracy	± 1%FS	± 1%FS	± 1%FS
Housing IP Degree	IP65	IP65	IP65
Connection	1-1/2"x5kg/cm ² or 1-1/2"PT Screw	1-1/2"PT	1-1/2"PT
Weight	Approx. 2.8kg(1M)	Approx. 2.3kg(1M)	Approx. 2.8kg(1M)
Operating pressure	15kg/cm ²	15kg/cm ²	15kg/cm ²

STANDARD SPECIFICATION

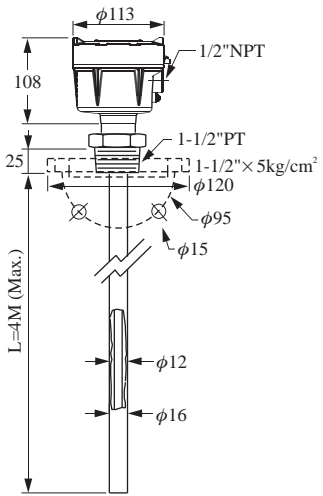
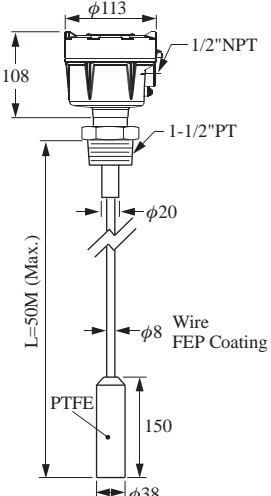
Dimensions (unit:mm)	 <p>EB2400 --- PVDF Coating EB2420 --- PP Coating EB2430 --- FEP Coating</p>	 <p>EB2510 --- Nylon Coating EB2520 --- PP Coating EB2530 --- FEP Coating</p>
Model No.	EB2400/20/30 Anti-Corrosion	EB2510/20/30 Anti-Corrosion
Probe material	SUS304+Coating	SUS304+Coating
Weight material	———	SUS304+PTFE
Ambient Temperature	-40~80°C	-40~80°C
Operating temperature	0~100°C	0~100°C
Tensile strength	———	1200Kgf
Operation voltage	12~36Vdc	12~36Vdc
Output current	4 ~20mA	4 ~20mA
Measuring Range	0~2000pF	0~2000pF
Accuracy	± 1%FS	± 1%FS
Housing IP Degree	IP65	IP65
Connection	1-1/2"x5kg/cm ²	1-1/2"PT
Weight	Approx. 2.3kg(1M)	Approx. 2.3kg(1M)
Operating pressure	15kg/cm ²	15kg/cm ²

SETTING FLOWCHART FOR EACH FUNCTION

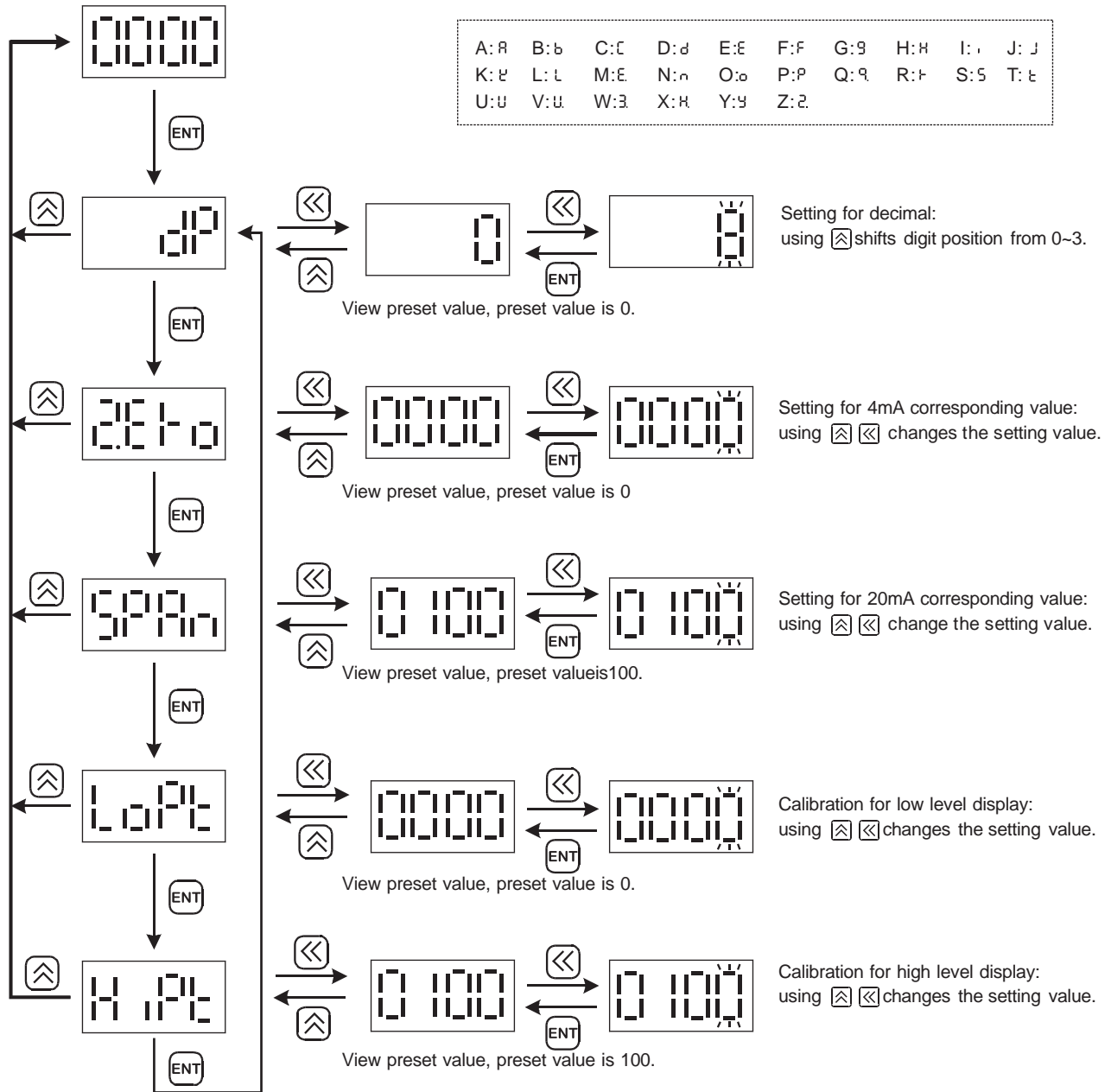

INSTALLATION

1. The rod probe or cable probe (depending upon which one you purchased) should be parallel to the tank wall and be positioned as close as possible to the tank wall. Make sure the medium does not stick in between the probe and the tank wall.
2. If the tank is not electrically conductive, a metal strap should be added outside of tank wall (fig. 1) for either liquid or non-liquid medium. Or place a metal tube, usually made out of stainless steel, around the rod (fig. 2) for liquid medium. This metal tube should come with a vent hole at top of the tube to allow the medium to go up inside of the tube.
3. If the container is irregular shaped, such as a cylindrical, and the medium is liquid with low viscosity, the rod should be place inside a metal tube with vent hole at the top. (fig. 2)
4. The cable probe should be routed through the ceramic insulator and tightened with the fixing bolt, finally it should be routed through the silo and firmly attached to the cable nut. (fig. 3)
5. Make sure to fix the rod probe or cable probe to the container wall with non-conductive supporting material. If an agitator is in place (see fig. 4). This will prevent the deformation of the rod probe and tangling of the cable probe around the agitator.
6. If the medium is conductive, make sure to coat the rod probe or cable probe with PVDF or PP material.
7. During the installation, the process connection should be grounded. An installation without proper grounding will not guarantee normal operation of the device later on.
8. When all electrical connections inside of a Capacitance Level Transducer housing are finished, the housing cover and the conduit opening should be sealed and tightened to prevent moisture from ruining it.

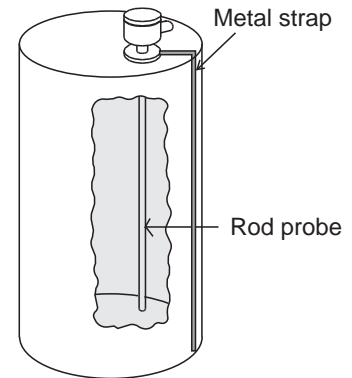

Fig. 1

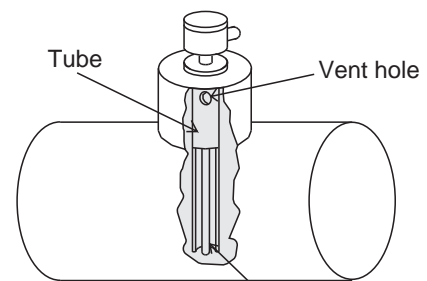

Fig. 2

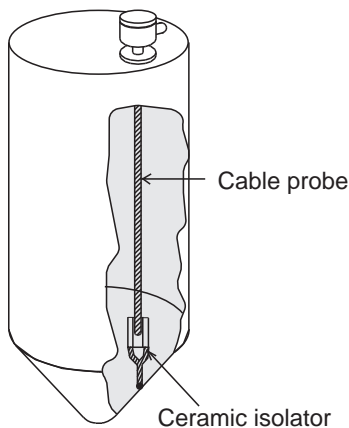

Fig. 3

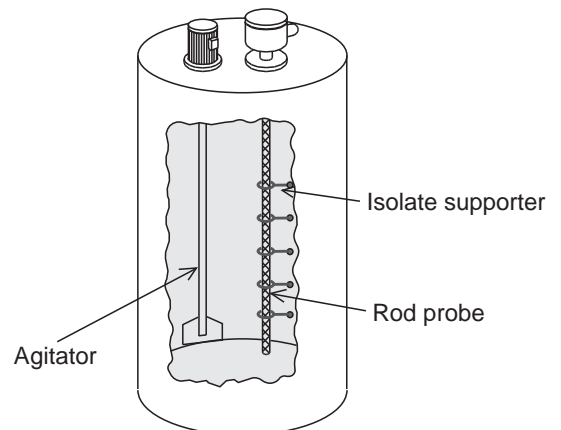

Fig. 4

CODE NAME INFORMATION

EB

Order No. _____

- EB2100 --- Wire-probe with Ceramic weight
- EB2200 --- Rod Type
- EB2300 --- Wire-probe weight Type
- EB24□□-- Anti-Corrosion
(2400: PVDF 2420: PP 2430: FEP)
- EB25□□-- Anti-Corrosion with Wire-probe weight
(2510: Nylon 2520: PP 2530: FEP)

Connecting _____

- | | |
|-------------------|--------------------------|
| B---1/2" | M---5kg/cm ² |
| C---3/4" | N---10kg/cm ² |
| D---1" | O---150 Lbs |
| E---1-1/2" | P---300 Lbs |
| F---2" | Q---PT pipe thread |
| G---2-1/2" | R---PF pipe thread |
| H---3" | T---BSP pipe thread |
| I---4" | U---NPT pipe thread |
| J---5" | V---G pipe thread |
| K---6" | S---Special spec. |
| S---Special spec. | |

Length L (UNIT: mm) _____

- * Tolerance of the total product length is ± 5 mm
- * Characteristics, specifications and dimensions are subject to change without notice.
- * Please contact your nearest distributing office for further informations.